

M7410E

SMALL MODULATING LINEAR VALVE ACTUATOR

PRODUCT DATA

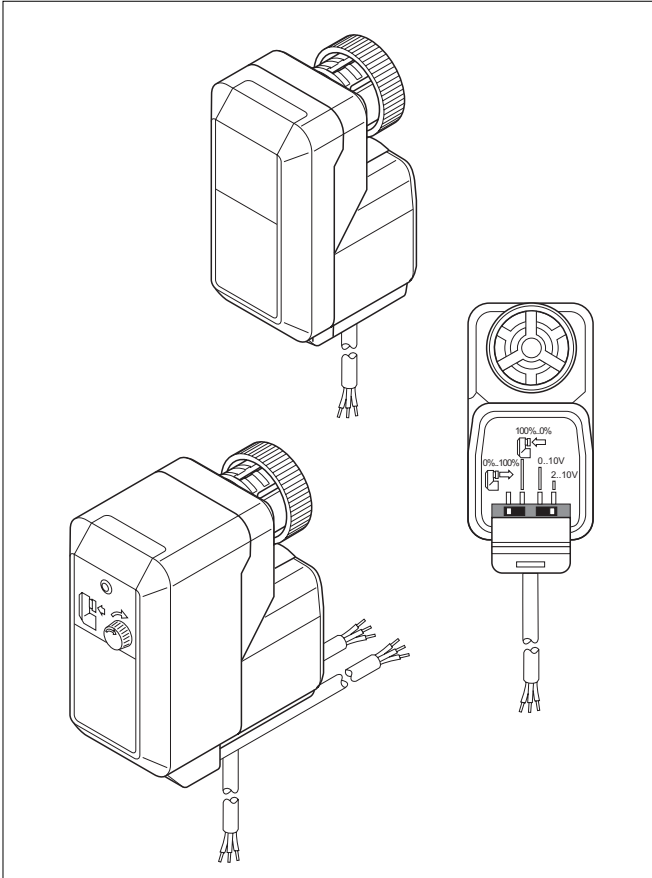

The Honeywell M7410E actuator is specifically designed to provide modulating control together with the V5822/23, V5832/33, and V5825B series of small linear valves.

The M7410E is used in fan-coil-units, induction units, small reheaters and recoolers, and for zone control applications. It is employed in electronic temperature control systems with hot and/or cold water as the controlled medium. This actuator is fully compatible with all controllers providing 0...10 V or 2...10 V output signals.

The 7410E actuator is designed for applications where space is limited and minimum power consumption is required. A microprocessor-based, high-performance positioner guarantees accurate control.

Reliable longtime operation is ensured due to the fact that no mechanical feedback potentiometer and no mechanical end-switches are needed. Due to an automatic synchronization function, the close-off point is self-adjusting.

Based on a running time of 150 s, valve positioning and flow adjustment is very exact. Manual positioning is provided for all actuators. The actuator is both attractive and robust in design. A special version with auxiliary switch is available.

APPLICATION FEATURES

- Microprocessor-based positioner ensures precise stem positioning
- Small size allows installation where space is limited
- Low power consumption
- Suitable for 0...10 V and 2...10 V controller output signal (adjustable on site)
- Easy-to-operate direct/reverse acting switch
- Simple input signal override (e.g. for frost protection function)
- Reliable longtime operation because mechanical feedback potentiometers and mechanical end switches are not required
- Magnetic coupling for stem force limitation and self-adjustment of the close-of-point
- Supplied with pre-wired connection cable
- Simple, standardized valve/actuator coupling. No tools required for mounting
- Visual valve position indicator furnished with actuator
- Manual operation provided by the valve adjustment cap, extra knob, or with a hexagon key

SPECIFICATIONS

Motor

Input voltage:	24 Vac \pm 15%; 50/60 Hz
Power consumption:	1.4 VA
Input signal:	modulating 0...10 V, 2...10 V (adjustable); <0.1 mA
Operation:	direct/reverse (adjustable)
Stroke:	6.5 mm
Running time:	150 s at 50 Hz 120 s at 60 Hz
Stem force:	depending on type (see table) 180 N (for valves DN 15..20) 300 N (for valves DN 25..40 and V5825B)
Protection standard:	IP 42 in accordance with EN 60529
Insulation class:	III in accordance with EN 60730
Connection cable:	1.5 m
Ambient operating temperature limits:	0...55 °C
Weight:	0.4 kg
Suitable valves:	see table
Manual operation:	see table

Auxiliary Switches

Ratings:	5...24 V max. 100 mA
	24...230 Vac, max. 3(1) A
Switch position (factory supplied):	Switch S1 (fix) 17.8 \pm 0.2 mm
	Switch S2 (adjust.) 11.7 \pm 0.2 mm

OPERATION

The movement of the electric actuator is produced by a screw spindle which is driven in both directions by a synchronous motor through a set of gears. A magnetic clutch limits the torque of the gear assembly and the driving force of the actuator. The actuator is fixed to the valve body by means of a coupling ring requiring no tools for mounting. The actuator is maintenance-free and supplied completely with a ready-to-wire connecting cable.

A microprocessor-based high performance positioner guarantees accurate control. The close-off position is self-adjusting by means of an automatic synchronization function. Synchronization is performed when the applied control signal is 0 V or 10 V. The actuator then drives every minute for 5 seconds into the end position in order to ensure close-off even after manual operation.

VERSIONS

	Manual operation	Stem force	Aux. switch S1	Aux. switch S2	Housing type	OS number
Standard	Provided by the valve adjustment cap	180 N	–	–	B	M7410E1002
		300 N	–	–	B	M7410E1028
With manual operation	Integrated "	180 N	–	–	C	M7410E2026
		300 N	–	–	C	M7410E2034
With manual operation and auxiliary switches	Integrated "	180 N	x	x	C	M7410E4022
		300 N	x	x	C	M7410E4030
Special versions	Special cable length length = 3 m / 5 m / 10 m					upon request

MOUNTING POSITION

The actuator may only be mounted beside or above the valve. Adjust the valve in the correct position before mounting the actuator.

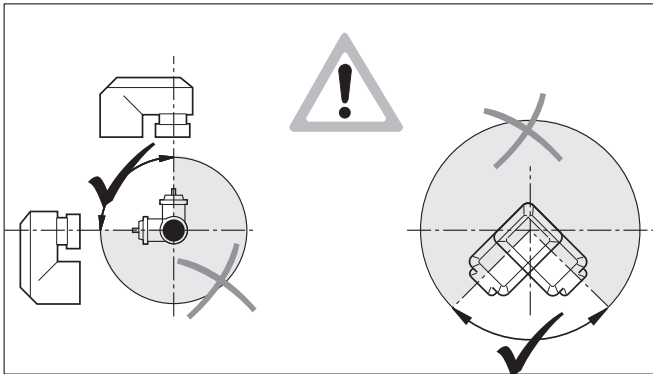

Fig. 1. Mounting positions

MOUNTING

Before the actuator is fixed to the valve, the adjustment cap must be removed (Fig. 2). Make sure that the actuator is in the open position (factory-supplied position) before fixing the actuator to the valve body.

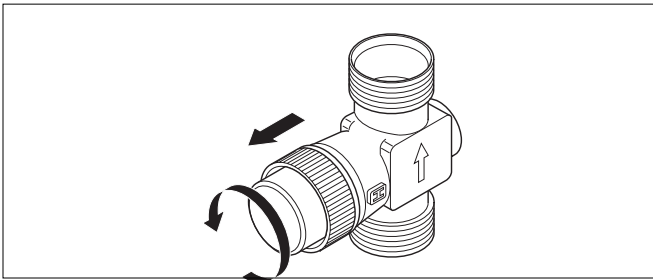

Fig. 2. Remove protection cap

The actuator must be mounted by hand. Do not use tools or additional force insofar as this may damage the actuator and valve.

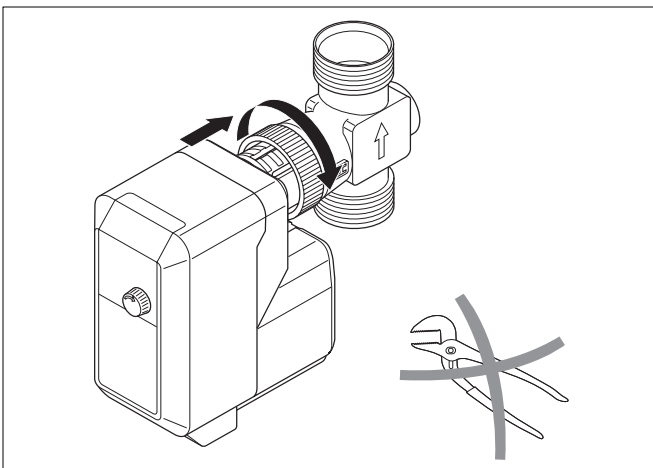

Fig. 3. Mounting the actuator

SWITCH SELECTION

The built-in selector switches must be set according to the valve type (2-way or 3-way), valve size, and the controller output signal (0...10 V or 2...10 V), see Fig. 4.

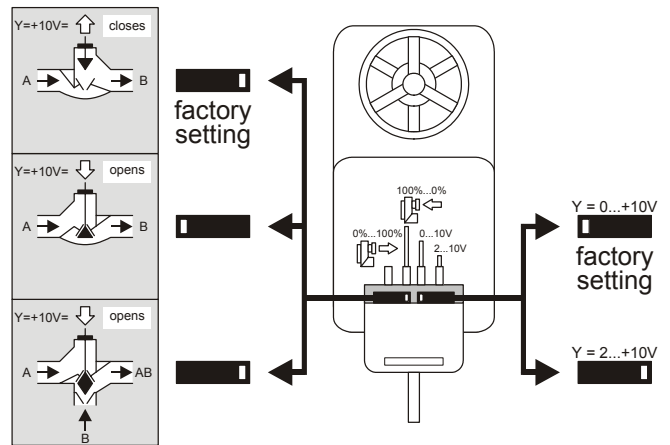

Fig. 4. Selecting valve type and output signal

ELECTRIC WIRING

The electrical installation must comply with Fig. 5.

INPUT SIGNAL OVERRIDE

To override the controller output signal, the input signal must be connected to COM (0 %) or 24 V (100 %) using an external switch (see Fig. 5).

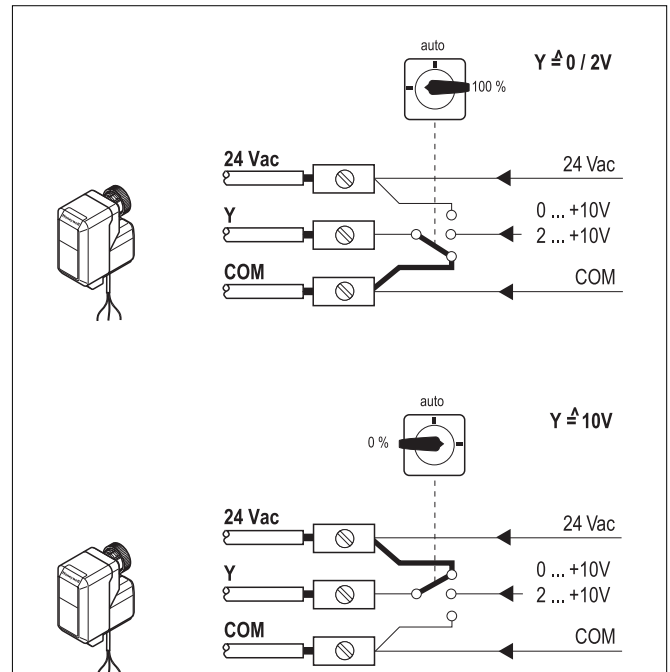

Fig. 5. Connection of input switch

MANUAL OPERATION

Actuators with the OS-number M7410E2... and M7410E4... feature a hexagonal key hole for manual operation. For more comfort, an additional knob for manual adjustment is packed separately. To prevent valve damage, operation is permitted only when there is no power applied to the motor.

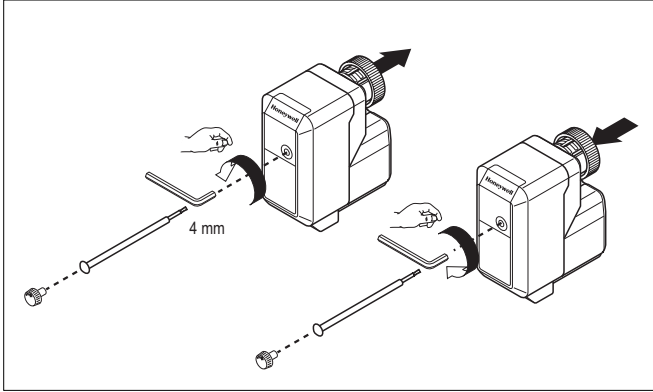

Fig. 6. Manual operation

COMMISSIONING ADVICE

A functional check of the valve actuator can be carried out by changing the Y input signal. The movement of the actuator stem (Fig. 7) indicates whether the valve is opening or closing. If the direction of travel is not correct, the direct/reverse-switch must be reset.

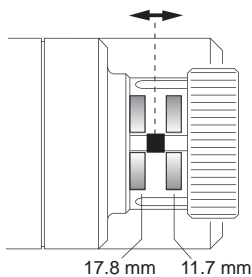

Fig. 7. Movement of the actuator stem

AUXILIARY SWITCHES

The actuators with the OS-number M7410E4022 and M7410E4033 feature 2 auxiliary switches. Each switch has its own cable. Auxiliary switch S1 with fixed switchpoint when the stem position is in. Auxiliary switch S2 with adjustable switchpoint when the stem position is out.

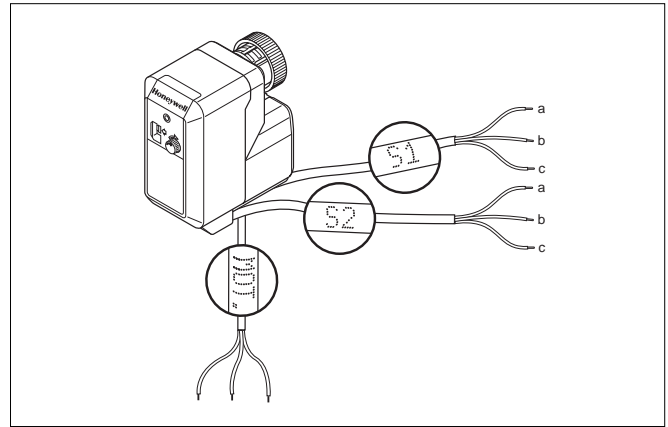

Fig. 8. Auxiliary switch cables

Adjustment of Auxiliary Switch 2

The auxiliary switch should be adjusted by a skilled person, only. Move the actuator to the position where the switch is to be operated. Cut the plastic skin with a sharp knife. The adjustment screw can be accessed below the skin. Turn the screw clockwise until the end stop is reached. Turn the screw counterclockwise until the switch point is achieved. To check that the required position has been set, move the actuator. Finally, seal the adjustment hole with a piece of tape.

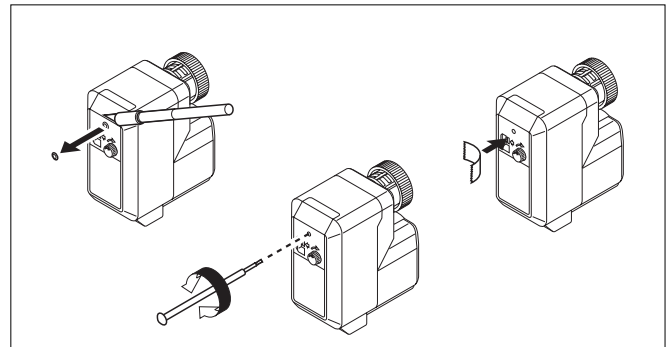

Fig. 9. Adjustment of auxiliary switch S2

Electric Wiring of Auxiliary Switches

The electrical installation must comply with the wiring diagram shown in Fig. 10. If the auxiliary switch is connected to 230 Vac, a switch with a contact gap of at least 3 mm for each pole must be fitted with the installation.

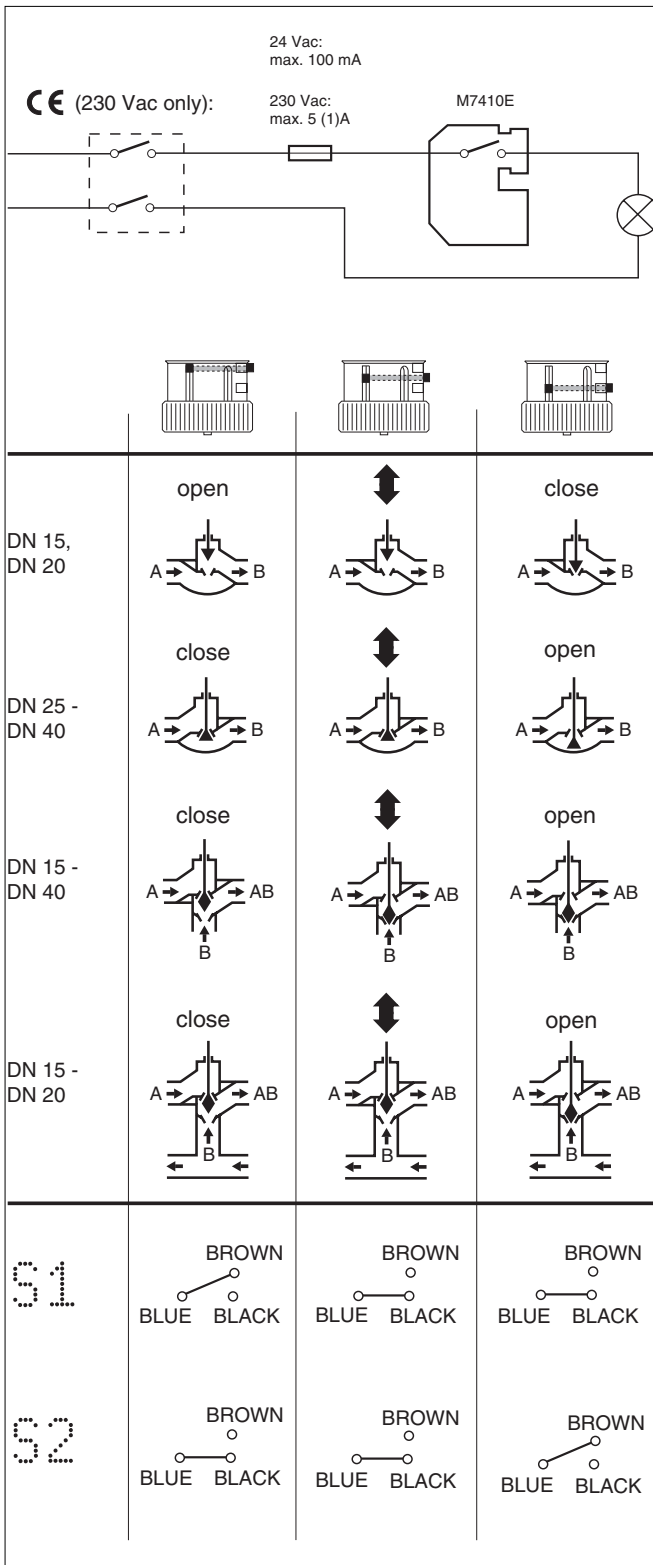

Fig. 10. Electric wiring of auxiliary switch

Application Example: Switching Off an Electrical Appliance 2-Way-Valve

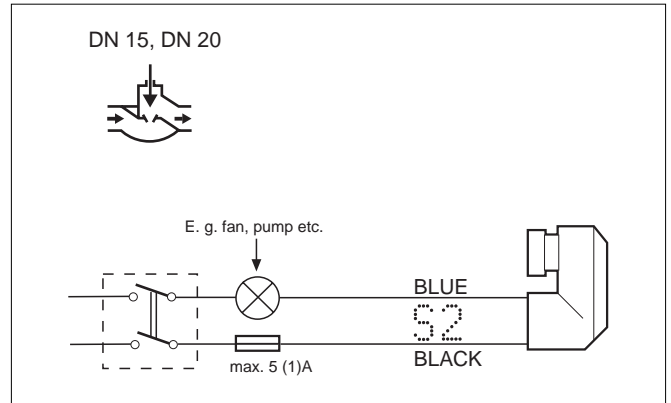

Fig. 11. Electric wiring of auxiliary switch

All Other Valves

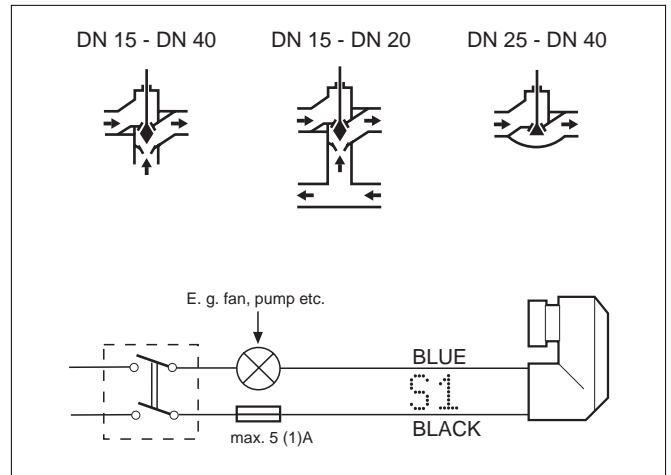

Fig. 12. Electric wiring of auxiliary switch

DIMENSIONS (MM)

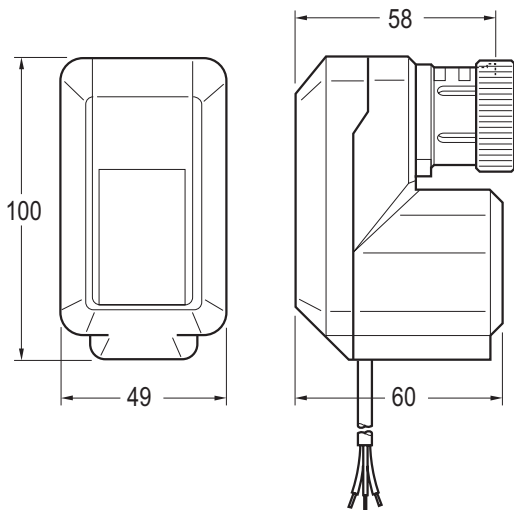

Fig. 13. Housing type B

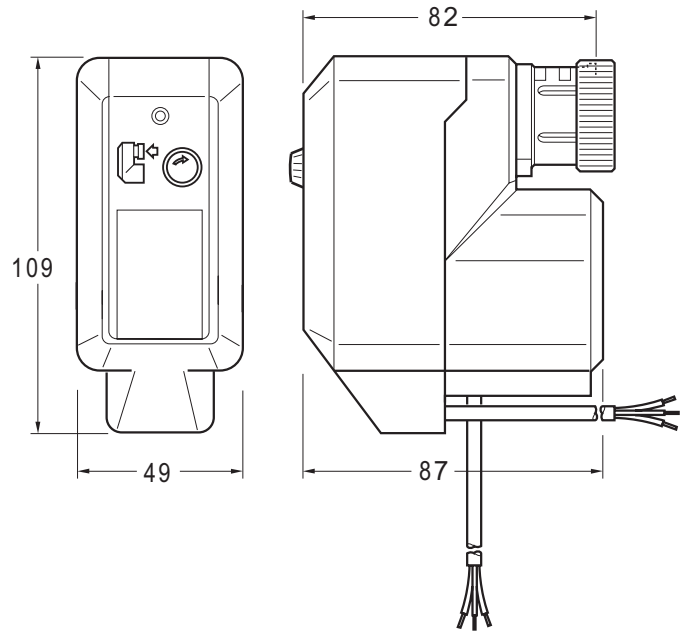

Fig. 14. Housing type C

Honeywell

Automation and Control Solutions

Honeywell GmbH
Böblinger Straße 17
D-71101 Schönaich
Phone: (49) 7031 63701
Fax: (49) 7031 637493
<http://europe.hbc.honeywell.com>

Subject to change without notice. Printed in Germany

EN0B-0097GE51 R1004

Manufacturing location certified to

DIN EN
ISO 9001