

N20, N34 SERIES

NON-SPRING RETURN DAMPER ACTUATOR

20/34 Nm (177/300 lb-in) FOR FLOATING / 2-POSITION CONTROL

PRODUCT DATA



GENERAL

These direct-coupled damper actuators provide floating and two-position control for:

- Air dampers
- VAV units
- Air handlers
- Ventilation flaps
- Louvers, and
- Reliable control for air damper applications with up to 4.6m² / 50 sq.ft. (20 Nm / 177 lb-in) or 7.8m² / 85 sq. ft. (34 Nm / 300 lb-in)(seal- less damper blades; air friction-dependent)

FEATURES

- **New self-centering shaft adapter**
- **Access cover to facilitate connectivity**
- **Declutch for manual adjustment**
- **Mechanical end limits (CN6120, CN4620 only)**
- **Field-installable auxiliary switches**
- **Rotation direction selectable by switch**
- **Mountable in any orientation (no IP54 if upside down)**
- **Mechanical position indicator**

SPECIFICATIONS

Supply voltage

CN6120/CN6134 24 Vac ± 15%, 50/60 Hz
CN4620/CN4634 230 Vac ± 15%, 50/60 Hz

Nominal voltage

CN6120/CN6134 24 Vac, 50/60 Hz
CN4620/CN4634 230 Vac, 50/60 Hz

All values stated hereinafter apply to operation under nominal voltage conditions.

Power consumption

CN6120 6 VA / 6 W
CN6134 9 VA / 9 W
CN4620 8 VA / 8 W
CN4634 13 VA / 10 W

Ambient limits

Ambient operating limits -20...+60 °C (-5...+140 °F)
Ambient storage limits -40...+80 °C (-40...+175 °F)
Relative humidity 5...95%, non-condensing

Safety

Protection standard IP54 as per EN 60529
Protection class II as per EN 60730-1
Overvoltage category II

Lifetime

Full strokes 60000
Repositions 1.5 million

Mounting

Round damper shaft 10...27 mm (3/8...1-1/16")
Square damper shaft 10...18 mm (3/8...11/16")
45° steps
Shaft length min. 22 mm (7/8")

Torque rating

CN6120/CN4620 20 Nm (177 lb-in)
CN6134/CN4634 34 Nm (300 lb-in)

Runtime

95 sec (60 Hz) / 110 sec (50 Hz)

Rotation stroke

95° ± 3°

Dimensions

see "Dimensions" on page 6

Weight

1.45 kg (3 lbs. 3 oz.)

Noise rating

40 dB(A) max. at 1 m

MODELS

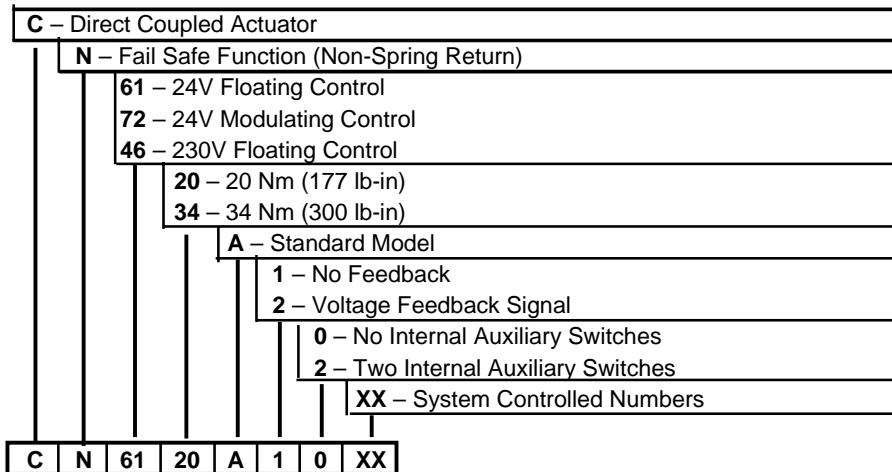
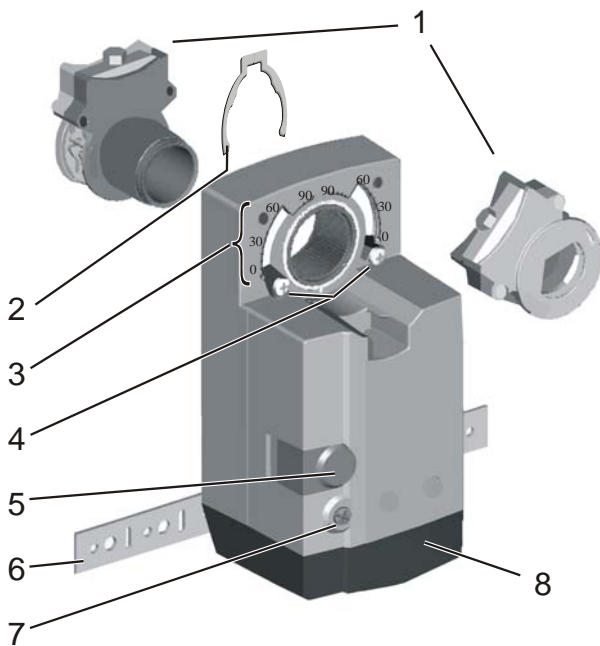

Fig. 1. Product Identification System

Model #	Description
CN6120A1002	20Nm,24Vac/Vdc, Floating control, Non-Spring Return, no feedback and without aux. Switch
CN4620A1001	20Nm,230V,Floating control, Non-Spring Return, no feedback and without aux. Switch
CN6134A1003	34Nm,24Vac/Vdc, Floating control, Non-Spring Return, no feedback and without aux. Switch
CN4634A1001	34Nm,230V, Floating control, Non-Spring Return, no feedback and without aux. Switch

OPERATION/FUNCTIONS



Legend for Fig. 2:

1. Self-centering shaft adapter
2. Retainer clip
3. Rotational angle scales (0...90° / 90...0°)
4. Mechanical end limits (20 Nm [177 lb-in] models, only)
5. Declutch button
6. Anti-rotation bracket
7. Rotation direction switch
8. Access cover

Contents of Package

The delivery package includes the actuator itself, parts 1 through 8 (see Fig.2), the anti-rotation bracket screws, and the SM mounting plate and screws.

Rotary Movement

The rotation direction (clockwise or counterclockwise) can be selected using the rotation direction switch (see part 7 in Fig. 2), thus eliminating the need to re-wire. To ensure tight closing of the dampers, the actuator has a total rotation stroke of 95°.

As soon as operating power is applied, the actuator may start to run. When power is removed, the actuator remains in position. For actuator-controller wiring instructions, see section "Wiring" on page 4.

Fig. 2. Setting units and control elements

ORDERING INFORMATION

When purchasing replacement and modernization products from your TRADELINE® wholesaler or distributor, refer to the TRADELINE® Catalog or price sheets for complete ordering number.

If you have additional questions, need further information, or would like to comment on our products or services, please write or phone your local Honeywell Automation and Control Products Sales Office or Honeywell Customer Care.

Rotation Direction Switch

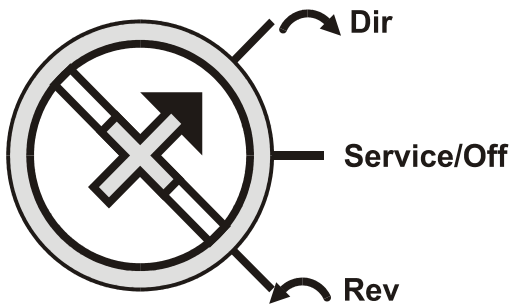

Fig. 3. Rotation Direction Switch

- **Dir** ("↻"): is the default shipping position. When the rotation direction switch is set to this position, the actuator internally switches the rotation direction control signals as stated in section "Wiring Diagrams" on pages 4 and 5.
- **"Service/Off"**: When the rotation direction switch is set to this position, all actuator rotary movement is cancelled and all control signals are ignored, thus enabling the actuator to be manually operated (see section "Manual Adjustment"). The user can then perform maintenance / commissioning without having to remove power from the actuator. To return to the control mode, simply move the rotation direction switch to its former setting.
- **Rev** ("↺"): When the rotation direction switch is set to this position, the actuator follows signals as stated in section "Wiring Diagrams" on pages 4 and 5.

Two-Position or Floating Control

The actuator is capable of being operated by either a two-position (open/close) or a floating (three-wire) controller. Refer to wiring diagrams for correct connection.

Position Indication

The hub adapter indicates the rotation angle position by means of the rotational angle scales (0...90° / 90...0°) provided in the actuator plate (see Fig. 4).

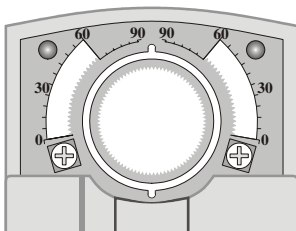

Fig. 4. Position indication

Manual Adjustment

IMPORTANT

To prevent equipment damage, you must remove power or set the rotation direction switch to the "Service/Off" position before manual adjustment.

After removing power or setting the rotation direction switch to the "Service/Off" position, the gear train can be disengaged using the declutch button, permitting the actuator shaft to be manually rotated to any position. The feedback signal will then follow the new position.

Limitation of Rotation Stroke

Two adjustable mechanical end limits (20 Nm [177 lb-in] models, only) are provided to limit the angle of rotation as desired (see Fig.5).

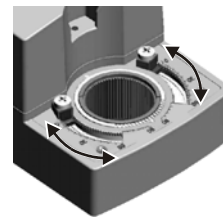

Fig. 5. Mechanical end limits

The mechanical end limits must be securely fastened in place as shown in Fig. 6. Specifically, it is important that they properly mesh with the rotational angle scales when the screws are tightened.

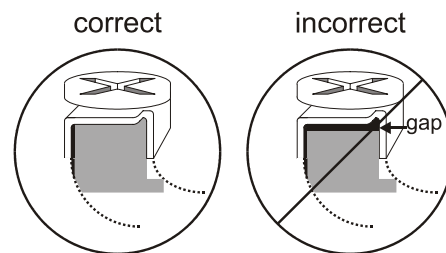

Fig.6. Correct / incorrect tightening of end limits

INSTALLATION

These actuators are designed for single-point mounting.

IMPORTANT

In order to prevent equipment damage, you must remove power or set the rotation direction switch to the "Service/Off" position before manual operation.

Mounting Instructions

All information and steps are included in the Installation Instructions supplied with the actuator.

Mounting Position

The actuators can be mounted in any position (no IP54 or NEMA2 if mounted upside down; see Fig. 7). Choose a mounting position permitting easy access to the actuator's cables and controls.

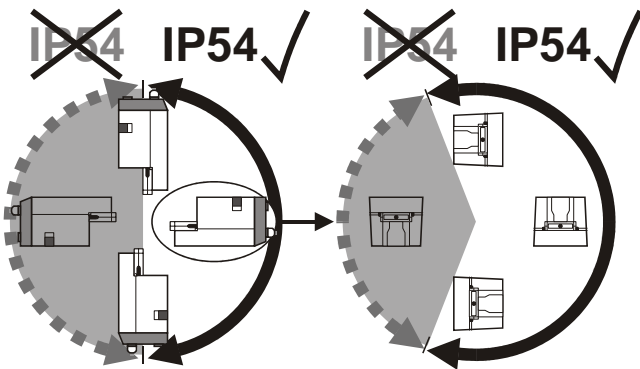

Fig. 7. Mounting for IP54

Mounting Bracket and Screws

If the actuator is to be mounted directly on a damper shaft, use the mounting bracket and screws included in the delivery package.

Self-Centering Shaft Adapter

The self-centering shaft adapter can be used for shafts having various diameters (10...27 mm [3/8...1-1/16"]) and shapes (square or round)

In the case of short shafts, the shaft adapter may be reversed and mounted on the duct side.

Stroke Limitation with Mechanical End Limits

The mechanical end limits (20 Nm [177 lb-in] models, only) enable the stroke to be limited from 0...90° in increments of 3°.

Wiring

Access Cover

To facilitate wiring the actuator to the controller, the access cover can be detached from the actuator.

IMPORTANT

Remove power before detaching the access cover. Once the access cover has been removed, please take care to avoid damaging any of the parts now accessible.

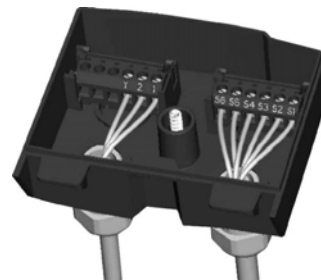

Fig. 8. Access cover

Depending upon the model, the access cover may have one or two terminal strips, including a layout with a description for each of the terminals.

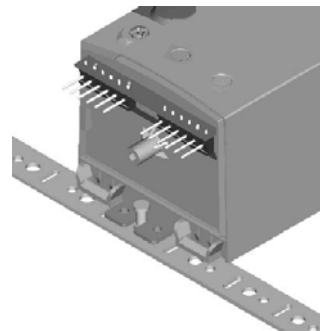
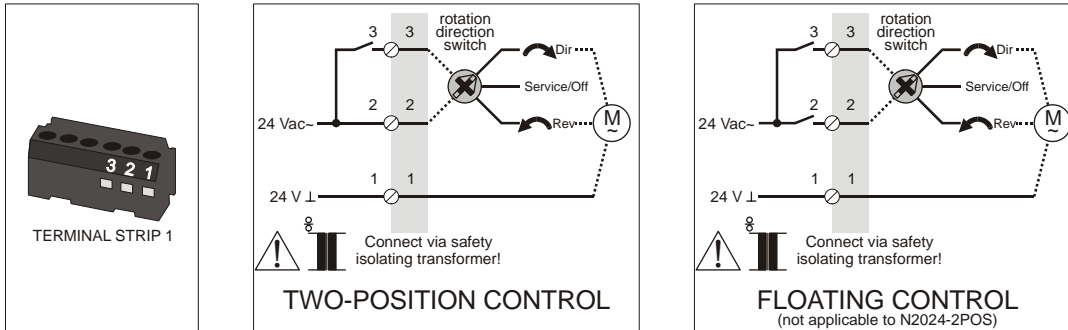

Fig. 9. Actuator with access cover removed

Wiring Diagrams

CN6120/CN6134



connecting cable	terminal	name	
		floating	two-position
supply and signal lines (must be equipped with spark suppressors)	1	24 Vac ⊥	24 Vac ⊥
	2	24 Vac (clockwise)	24 Vac ~
	3	24 Vac (counterclockwise)	24 Vac control signal

CN4620/CN4634

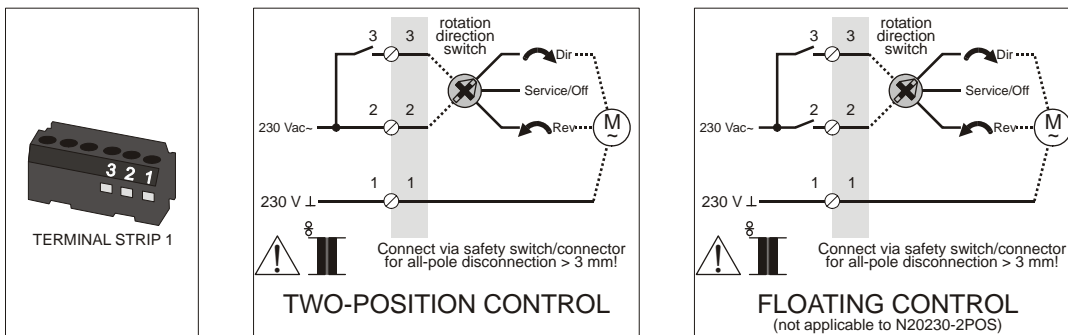

connecting cable	terminal	name	
		floating	two-position
supply and signal lines (must be equipped with spark suppressors)	1	230 Vac ⊥	230 Vac ⊥
	2	230 Vac (clockwise)	230 Vac ~
	3	230 Vac (counterclockwise)	230 Vac control signal

Optional Accessories

The following optional accessories can be ordered separately.

Auxiliary Switch Kit

Order no.: SW2

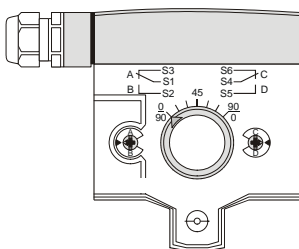

Dimensions

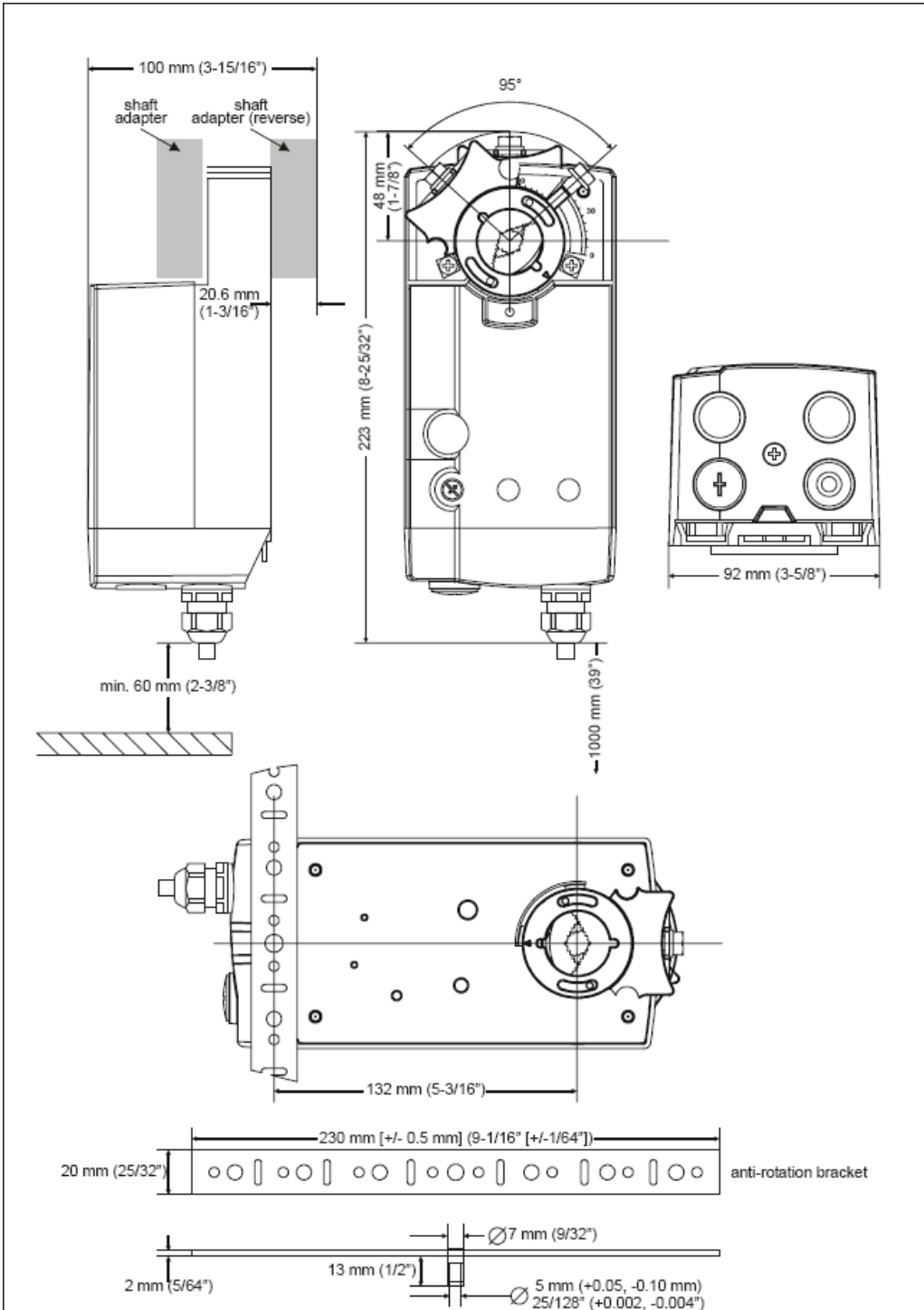

Automation and Control Solutions
 Honeywell International Inc.
 1985 Douglas Drive North
 Golden Valley, MN 55422

Honeywell (Tianjin) Limited
 66, BaiHe Road, TEDA
 Tianjin, 300457, P.R.C.

Honeywell



Printed in China, on recycled paper containing at least 10% post-consumer paper fibers.