

N05, N10 SERIES

NON-SPRING RETURN DIRECT-COUPLED DAMPER ACTUATORS FOR FLOATING AND TWO-POSITION CONTROL

PRODUCT DATA



GENERAL

This non-spring return direct-coupled damper actuator provides floating and two-position control for:

- air dampers,
- VAV units,
- air handlers,
- ventilation flaps,
- louvers, and
- reliable control for air damper applications with up to 10 sq ft / 44 lb-in. (5 Nm) and 20 sq ft / 88 lb-in. (10 Nm) (seal-less damper blades; air friction-dependent).

FEATURES

- **Declutch for manual adjustment**
- **Adjustable mechanical end limits**
- **Removable access cover for direct wiring**
- **Mountable in any orientation**
- **Rotation direction and service/OFF switch**

SPECIFICATIONS

Supply voltage CN6105/CN6110	24 Vac/dc -15%/+20%, 50/60 Hz
Nominal voltage CN6105/CN6110	24 Vac/dc, 50/60 Hz
All values stated hereinafter apply to operation under nominal voltage conditions.	
Power consumption CN6105/CN6110	5 VA / 2 W
Ambient limits Ambient operating limits Ambient storage limits Relative humidity	-5...+140 °F (20...+60 °C) -22...+176 °F (-30...+80 °C) 5...95%, non-condensing
Safety Protection standard Protection class Overvoltage category	IP54 II as per EN 60730-1 II
Lifetime Full strokes Repositions	60000 1.5 million
Mounting Round damper shaft Square damper shaft Shaft length	3/8 in...5/8 in. 1/4 in...1/2 in.; 45° steps min. 1-5/8 in.
End switches (when included) Rating Triggering points Torque rating	Class II 5° / 85° 44 lb-in. (5Nm) / 88 lb-in. (10 Nm)
Runtime for 90° CN6105 CN6110	90 sec (dc / 60 Hz ac) 90 sec (dc / 50 Hz ac)
Rotation stroke	95° ± 3°
Dimensions	see "Dimensions" on page 6
Weight (without cables)	1 lbs.
Noise rating	35 dB(A) max. at 1 m

PRODUCT IDENTIFICATION SYSTEM

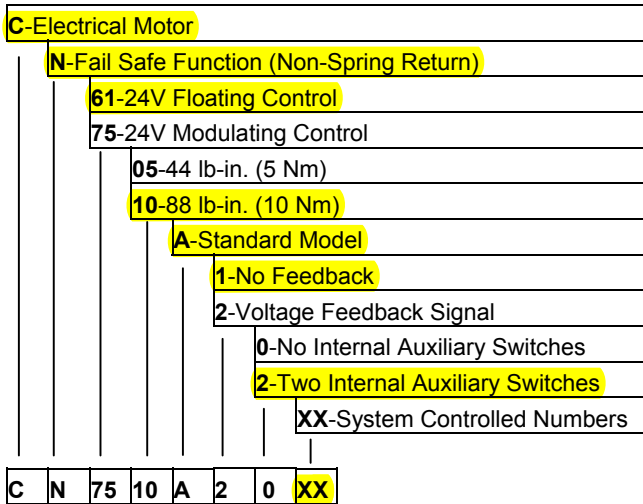

BASIC FEATURES

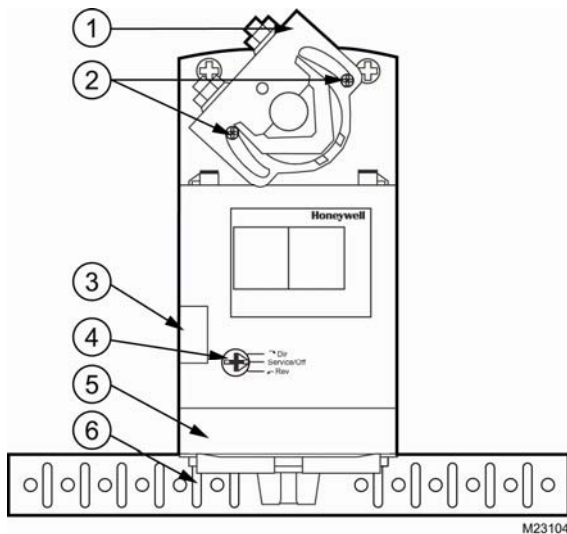

Fig. 1. Setting units and control elements

Legend for Fig. 1:

- 1) Universal shaft adapter
- 2) Mechanical end limits (manually adjustable)
- 3) Declutch button
- 4) Function selection switch
- 5) Removable access cover
- 6) Anti-rotation bracket

Contents of Package

The delivery package includes the actuator, parts 1 through 6 (see Fig. 1), plus two cable grommets and a spare cable grommet.

RUN MODES

The function selection switch (see Fig. 2) can be used to place the actuator into any one of two different modes:

- Service/Off; or
- the floating/2-position run mode (“Dir” for CCW-closing dampers or “Rev” for CW-closing dampers).



Fig. 2. Function selection switch

Power-Off Behavior

If power is removed, the shaft adapter remains in position.

Service/Off

If the function selection switch is set to the “Service/Off” position, then all rotary movement is cancelled, and all control signals are ignored, thus allowing the actuator to be manually operated safely.

Floating/2-Position Run Mode

If the function selection switch has been set to one of the two floating/2-position control settings—and if the actuator is wired correspondingly (see Fig. 7, Fig. 8, and Fig. 9)—then as soon as operating power is applied, the shaft adapter will run according to the control signals applied.

Table 1 describes the behavior (“stops,” rotates “CCW,” or rotates “CW”) of the CN6105/CN6110 in dependence upon the control signals (switch “open” or “24 Vac/dc”) applied to terminals 3 and 4, the function selection switch setting, and the manner in which the actuator is wired (either for floating mode: see Fig. 7; or for 2-position mode: see Fig. 8).

Table 1. Behavior of CN6105/CN6110

wiring	control signal at		switch setting		
	term 3	term 4	Dir	Service/Off	Rev
float.	open	open	stops	stops	stops
	open	24Vac/dc	CCW	stops	CW
	24Vac/dc	open	CW	stops	CCW
2-pos.	24Vac/dc	open	CW	stops	CCW
	24Vac/dc	24Vac/dc	CCW	stops	CW

MANUAL ADJUSTMENT

IMPORTANT

To prevent equipment damage, before manual adjustment, you must remove power or set the function selection switch to the “Service/Off” position.

After removing power or setting the function selection switch to the “Service/Off” position, the gear train can be disengaged using the declutch button, permitting the shaft adapter to be manually rotated to any position.

Limitation of Rotation Stroke

Two adjustable mechanical end limits are provided to limit the angle of rotation as desired (see Fig. 3). The mechanical end limits must be securely fastened in place.

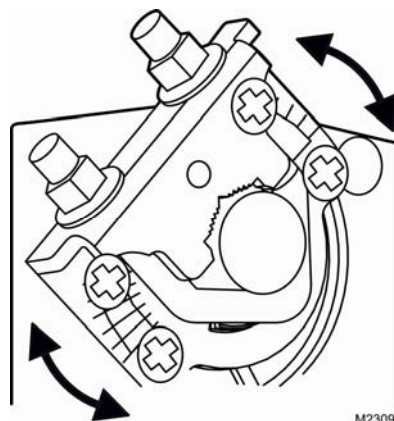

Fig.3. Mechanical end limits

To ensure tight closing of the dampers, the shaft adapter has a total rotation stroke of 95°.

INTERNAL END SWITCHES

The internal end switches “A” and “B” are changeover switches which are activated when the shaft adapter moves past a position of 5° and 85°, respectively (see also Table 3).

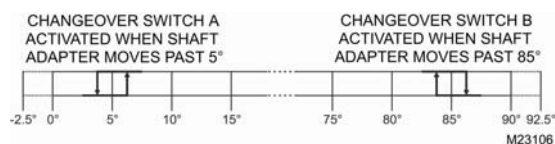

Fig.4. Internal end switch triggering points

INSTALLATION

To avoid personal injury (electrical shock) and to prevent equipment damage, before installation, you must remove power.

These actuators are designed for single-point mounting.

Mounting Instructions

All information and steps are included in the Installation Instructions (Product Literature No. 62-0224) supplied with each actuator.

Mounting Position

The actuators can be mounted in any position (IP54 is dependent upon orientation; see Fig. 8). Choose a mounting position permitting easy access to cables and controls.

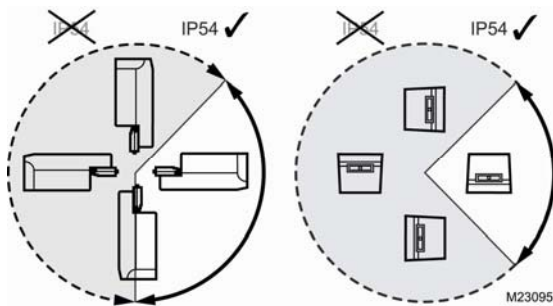

Fig. 5. Mounting for IP54

NOTE: Further, in order to guarantee IP54, only original Honeywell grommets may be used.

Anti-Rotation Bracket and Screws

If the actuator is to be mounted directly on a damper shaft, use the anti-rotation bracket and screws included in the delivery package. The min. distance between the center of the damper shaft and the middle of the anti-rotation bracket is 3.35 in.; a max. of 4.25 in. is allowed (see also Fig 10).

Depending upon the specifics of your mounting site, the actuator may shift in position slightly while tightening the screws at the top of the shaft adapter. The anti-rotation bracket features a T-piece with a 5-mm-long shank to accommodate for this movement. It is important to ensure that this play is not impeded.

Universal Shaft Adapter

The universal shaft adapter can be used for shafts of various diameters and shapes (round: 3/8...5/8 in. and square: 1/4...1/2 in.).

WIRING

CAUTION

To avoid personal injury (electrical shock) and to prevent equipment damage, before wiring, you must remove power.

Access Cover

IMPORTANT

Once the access cover has been removed, please take care to avoid damaging any of the parts now accessible.

The access cover can be unscrewed and removed in order to gain access to the terminal block(s) and perform wiring.

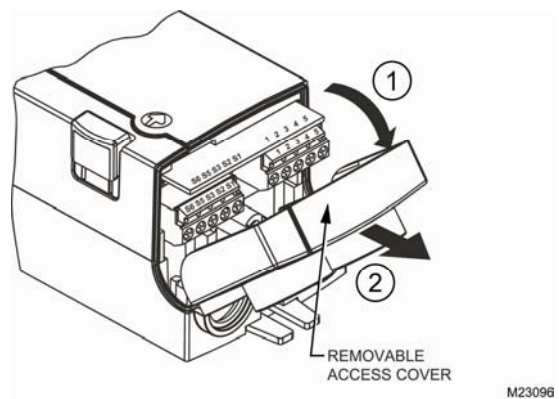

Fig. 6. Access Cover

Wiring Diagrams

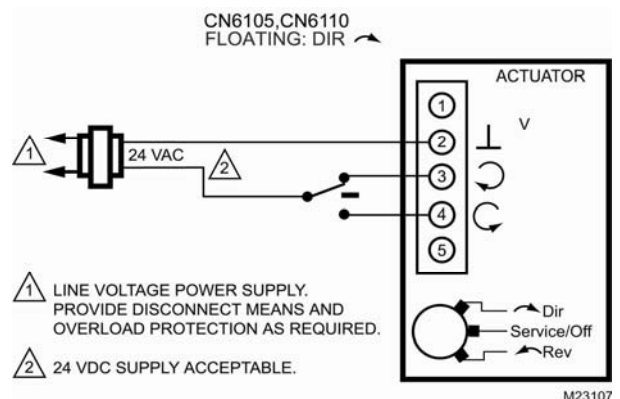

Fig. 7. CN6105/CN6110 (floating mode)

N05,N10 SERIES DAMPER ACTUATORS FOR FLOATING/2-POSITON CONTROL

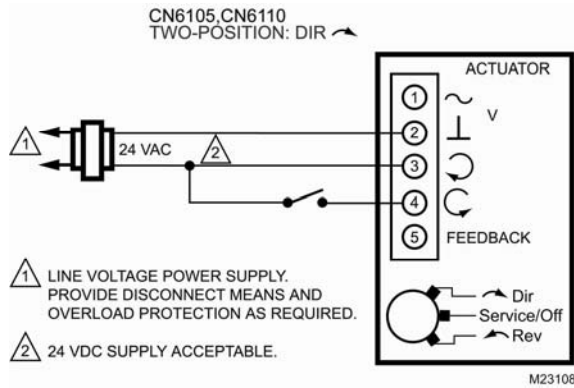

Fig. 8. CN6105/CN6110 (2-position mode)

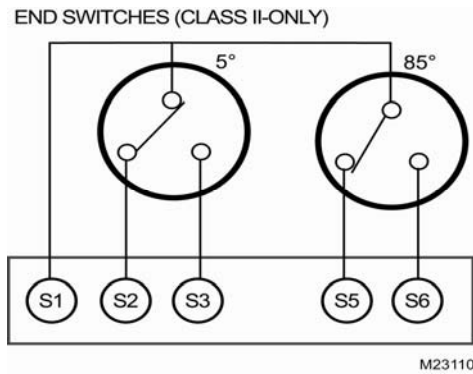

Fig. 9. End switches

NOTE: Both internal end switches must be connected to the same power source.

Tables 2 and 3 summarize the information presented in the preceding wiring diagrams.

Table 2. Signals at terminals for CN6105/CN6110

terminal	signal in floating	signal in 2-pos. mode
2	common ~/-	common ~/-
3	24 V ~/+ (control signal)	24 V ~/+ (control/ power signal)
4	24 V ~/+ (control signal)	24 V ~/+ (control signal/power)

NOTE: All cables connected to these terminals must be equipped with spark suppression.

Table 3. Internal end switches

terminal	type of switch
S1	common lead for switches A and B
S2/S3	change-over switch A (S1/S2 opens and S1/S3 closes when shaft adapter moves CW past 5°; reverts to original state when shaft adapter moves CCW past 5°).
S5/S6	change-over switch B (S1/S6 closes when shaft adapter moves CW past 85°; reverts to original state when shaft adapter moves CCW past 85°).

DIMENSIONS

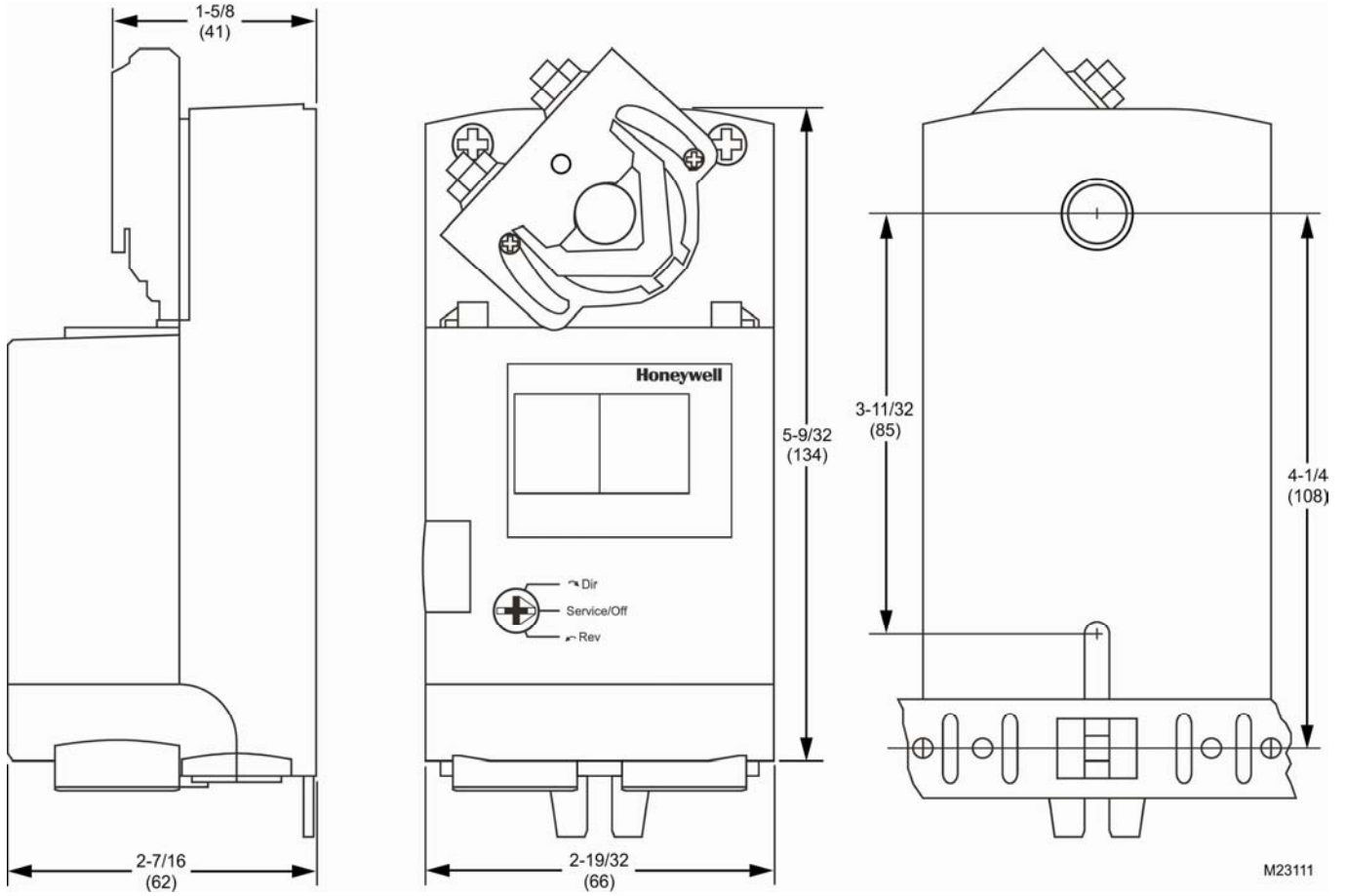

Fig. 10. Dimensions (in in.)

N05, N10 SERIES DAMPER ACTUATORS FOR FLOATING/2-POSITION CONTROL

N05, N10 SERIES DAMPER ACTUATORS FOR FLOATING/2-POSITION CONTROL

Automation and Control Solutions

Honeywell International Inc.
1985 Douglas Drive North
Golden Valley, MN 55422

Honeywell (Tianjin) Limited
66, BaiHe Road, TEDA
Tianjin, 300457, P.R.C.

Honeywell



Printed in China, on recycled
paper containing at least 10%
post-consumer paper fibers.